

# OS1

## Mid-Range High-Resolution Imaging Lidar



**FIRMWARE VERSION: 3.x**

**HARDWARE VERSION: REV7**

### SUMMARY

The mid-range OS1 lidar sensor features 90 m range on a dark 10% target, a 45° vertical field of view, and high reliability for the most rugged conditions. The OS1 is designed for all-weather environments and use in industrial automation, autonomous vehicles, mapping, smart infrastructure, and robotics.

### HIGHLIGHTS

- 100% increase in range with the new L3 Chip
- Dual Return mode
- Calibrated reflectivity
- Fixed resolution per frame
- Camera-grade near-infrared and signal data
- Multi-sensor crosstalk suppression
- Open source ROS and C++ drivers
- Ouster SDK for software development

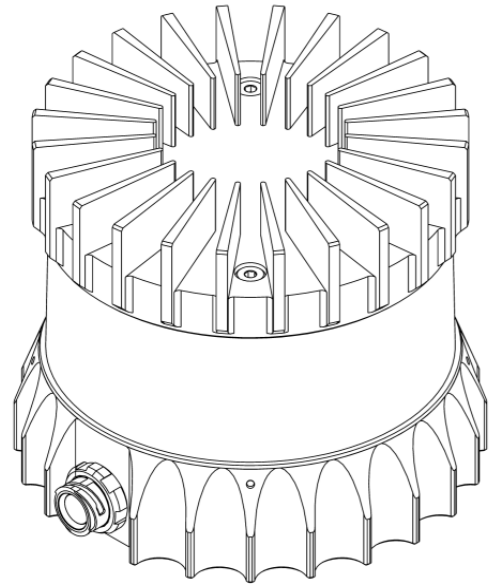

### OPTICAL PERFORMANCE

Range (80% Lambertian reflectivity, 1024 @ 10 Hz mode)	170 m @ >90% detection probability, 100 klx sunlight
Range (10% Lambertian reflectivity, 1024 @ 10 Hz mode)	90 m @ >90% detection probability, 100 klx sunlight
Minimum Range	0.5 m (to be reduced in FW 3.1)
Vertical Resolution	32, 64, or 128 channels
Horizontal Resolution	512, 1024, or 2048 (configurable)
Rotation Rate	10 or 20 Hz (configurable)
Field of View	Vertical: 45° (+22.5° to -22.5°) Horizontal: 360°
Angular Sampling Accuracy	Vertical: ±0.01° / Horizontal: ±0.01°
False Positive Rate	1/10,000
Range Resolution	0.1 cm <b>Note:</b> For <i>Low Data Rate Profile</i> the Range Resolution = 0.8cm
# of Returns	2 (strongest, second strongest)

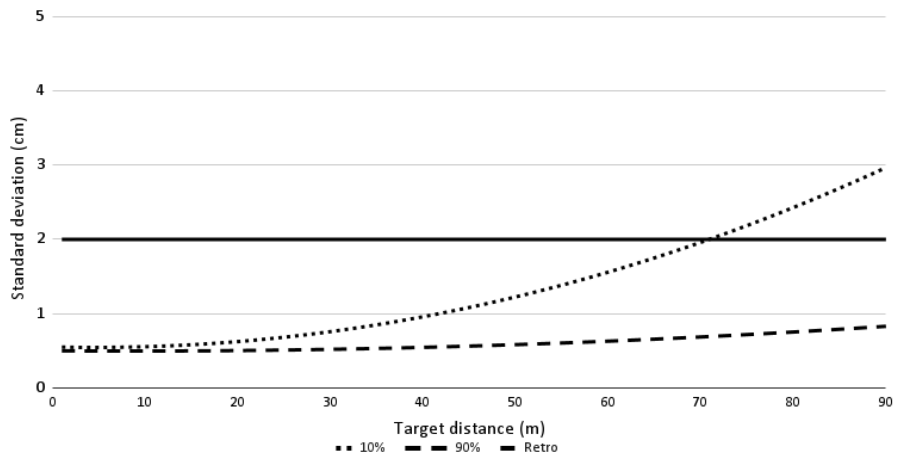
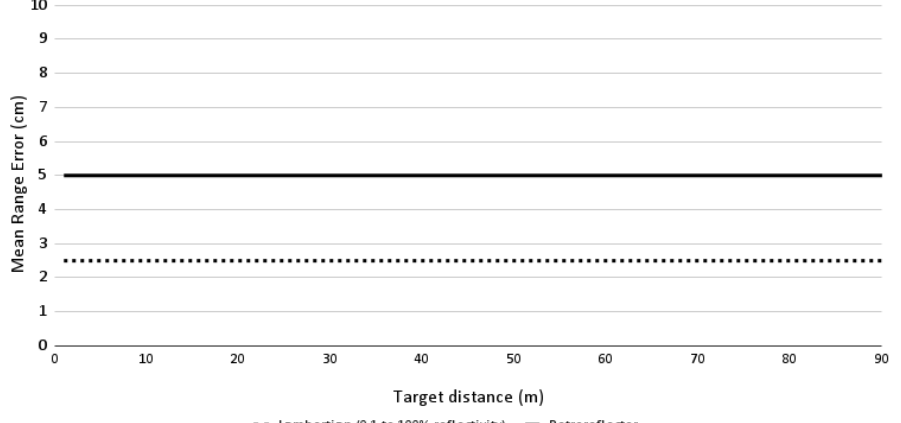
<p>Precision (Typical on Lambertian and Retroreflective, 1024 @ 10 Hz mode, 1 standard deviation)</p>	<p>Min: <math>\pm 0.5</math> cm, Max: <math>\pm 3</math> cm</p>  <table border="1"> <caption>Standard deviation (cm) vs Target distance (m)</caption> <thead> <tr> <th>Target distance (m)</th> <th>10%</th> <th>90%</th> <th>Retro</th> </tr> </thead> <tbody> <tr><td>0</td><td>0.5</td><td>0.5</td><td>2.0</td></tr> <tr><td>10</td><td>0.5</td><td>0.5</td><td>2.0</td></tr> <tr><td>20</td><td>0.6</td><td>0.5</td><td>2.0</td></tr> <tr><td>30</td><td>0.8</td><td>0.5</td><td>2.0</td></tr> <tr><td>40</td><td>1.2</td><td>0.5</td><td>2.0</td></tr> <tr><td>50</td><td>1.6</td><td>0.5</td><td>2.0</td></tr> <tr><td>60</td><td>2.0</td><td>0.5</td><td>2.0</td></tr> <tr><td>70</td><td>2.4</td><td>0.5</td><td>2.0</td></tr> <tr><td>80</td><td>2.8</td><td>0.5</td><td>2.0</td></tr> <tr><td>90</td><td>3.0</td><td>0.5</td><td>2.0</td></tr> </tbody> </table>	Target distance (m)	10%	90%	Retro	0	0.5	0.5	2.0	10	0.5	0.5	2.0	20	0.6	0.5	2.0	30	0.8	0.5	2.0	40	1.2	0.5	2.0	50	1.6	0.5	2.0	60	2.0	0.5	2.0	70	2.4	0.5	2.0	80	2.8	0.5	2.0	90	3.0	0.5	2.0
Target distance (m)	10%	90%	Retro																																										
0	0.5	0.5	2.0																																										
10	0.5	0.5	2.0																																										
20	0.6	0.5	2.0																																										
30	0.8	0.5	2.0																																										
40	1.2	0.5	2.0																																										
50	1.6	0.5	2.0																																										
60	2.0	0.5	2.0																																										
70	2.4	0.5	2.0																																										
80	2.8	0.5	2.0																																										
90	3.0	0.5	2.0																																										
<p>Range Accuracy <b>Note:</b> "Accuracy is calculated based on the error between the mean of 100 measurements on static target at a given range and the true range"</p>	 <table border="1"> <caption>Mean Range Error (cm) vs Target distance (m)</caption> <thead> <tr> <th>Target distance (m)</th> <th>Lambertian (0.1 to 100% reflectivity)</th> <th>Retroreflector</th> </tr> </thead> <tbody> <tr><td>0</td><td>2.5</td><td>5.0</td></tr> <tr><td>10</td><td>2.5</td><td>5.0</td></tr> <tr><td>20</td><td>2.5</td><td>5.0</td></tr> <tr><td>30</td><td>2.5</td><td>5.0</td></tr> <tr><td>40</td><td>2.5</td><td>5.0</td></tr> <tr><td>50</td><td>2.5</td><td>5.0</td></tr> <tr><td>60</td><td>2.5</td><td>5.0</td></tr> <tr><td>70</td><td>2.5</td><td>5.0</td></tr> <tr><td>80</td><td>2.5</td><td>5.0</td></tr> <tr><td>90</td><td>2.5</td><td>5.0</td></tr> </tbody> </table>	Target distance (m)	Lambertian (0.1 to 100% reflectivity)	Retroreflector	0	2.5	5.0	10	2.5	5.0	20	2.5	5.0	30	2.5	5.0	40	2.5	5.0	50	2.5	5.0	60	2.5	5.0	70	2.5	5.0	80	2.5	5.0	90	2.5	5.0											
Target distance (m)	Lambertian (0.1 to 100% reflectivity)	Retroreflector																																											
0	2.5	5.0																																											
10	2.5	5.0																																											
20	2.5	5.0																																											
30	2.5	5.0																																											
40	2.5	5.0																																											
50	2.5	5.0																																											
60	2.5	5.0																																											
70	2.5	5.0																																											
80	2.5	5.0																																											
90	2.5	5.0																																											

### LASER

Laser Product Class	Class 1 eye-safe per IEC/EN 60825-1: 2014
Laser Wavelength	865 nm
Beam Diameter Exiting Sensor	9.5 mm
Beam Divergence	0.18° (FWHM)

### LIDAR OUTPUT

Connection	UDP over gigabit Ethernet
Points Per Second	1,310,720 (32 channel) 2,621,440 (64 channel) 5,242,880 (128 channel)
Data Rate (Megabits Per Second) (Legacy Mode) 2048x10	66 Mbps (32 channel) 129 Mbps (64 channel) 254 Mbps (128 channel)
Data Rate (Megabits per second) (Dual Return Profile at highest resolution 2048x10)	up to 86.55 Mbps (32 channel) up to 170.43 Mbps (64 channel) up to 338.20 Mbps (128 channel)



Data Rate (Megabits per second) (Low Data Rate Profile)	up to 23.6 Mbps (32 channel) up to 44.6 Mbps (64 channel) up to 86.6 Mbps (128 channel)
Data Rate (Megabits per second) (Single Return Profile)	up to 65.6 Mbps (32 channel) up to 128.5 Mbps (64 channel) up to 254.3 Mbps (128 channel)
Data Per Point	Range, signal, reflectivity, near-infrared, channel, azimuth angle, timestamp
Timestamp Resolution	< 1 $\mu$ s
Data Latency	< 10 ms

### IMU OUTPUT

Connection	UDP over 1000Base-T or 1000Base-T1
Samples Per Second	100
Data Per Sample	3 axis gyro, 3 axis accelerometer
Timestamp Resolution	< 1 $\mu$ s
Data Latency	< 10 ms
Additional Details	InvenSense IAM-20680HT; datasheet for more details: <a href="https://invensense.tdk.com/download-pdf/iam-20680ht-datasheet/">https://invensense.tdk.com/download-pdf/iam-20680ht-datasheet/</a>

### CONTROL INTERFACE

Connection	TCP and HTTP APIs
Time Synchronization	Input sources: <ul style="list-style-type: none"> <li>• IEEE1588 Precision Time Protocol (PTP); Accuracy: &lt;1 ms error</li> <li>• gPTP; Accuracy: &lt;1 ms error</li> <li>• NMEA \$GPRMC UART message support</li> <li>• External PPS; Accuracy: &lt;1 ms error</li> <li>• Internal 10 ppm drift clock; Accuracy: &lt;20 ppm error</li> </ul> Output sources: <ul style="list-style-type: none"> <li>• Configurable 1 - 60 Hz output pulse</li> </ul>
Lidar Operating Modes	Hardware-triggered angle firing (guaranteed fixed resolution per rotation): <ul style="list-style-type: none"> <li>• x 512 @ 10 Hz or 20 Hz</li> <li>• x 1024 @ 10 Hz or 20 Hz</li> <li>• x 2048 @ 10 Hz</li> </ul>
Additional Programmability	Multi-sensor Phase Lock Azimuth Masking Low-power Standby Mode Queryable intrinsic calibration information: <ul style="list-style-type: none"> <li>• Beam angles</li> <li>• IMU pose correction matrix</li> </ul>



### MECHANICAL/ELECTRICAL

Power Consumption	14 - 20 W (22 W peak at startup, 28 W peak if operating at -40 °C) <b>Note:</b> "Ouster recommends use of a power brick (no less than 30 W) if using in extreme outdoor conditions."
Connector	Proprietary pluggable connector (Power + data + DIO)



Operating Voltage	<ul style="list-style-type: none"> <li>• Suitable for 12VDC and 24VDC Nominal systems.</li> <li>• <b>Not</b> suitable for 48V nominal battery based systems.</li> <li>• Under voltage conditions/alarms occur at 9.5VDC at connector.</li> <li>• Over voltage conditions/alarms occur at 51VDC at connector.</li> <li>• Overvoltage lockout onset at 58VDC (<math>\pm 1V</math>) at connector.</li> <li>• Overvoltage lockout release: 55VDC (<math>\pm 1V</math>) at connector.</li> </ul>
Dimensions	Diameter: 87 mm (3.42 in) Height: <ul style="list-style-type: none"> <li>• Without cap: 58.35 mm (2.3 in)</li> <li>• With thermal cap: 74.2 mm (2.9 in)</li> </ul>
Weight	Without cap: 420 g (14.8 oz) With radial cap: 495 g (17.4 oz) With halo cap: 440 g (15.5 oz)
Mounting	Bottom: 4x M3 screws, 2x locating 2 mm pin holes Top: 4x M3 screws, 4x locating 2 mm pin holes, 1x M6 screw

### OPERATIONAL

Operating Temperature	-40 °C to +60 °C (with mount) Between +53 °C and +60 °C, sensor automatically reduces range (max 20% range reduction)
Storage Temperature	-40 °C to +105 °C
Ingress Protection	IP68 (1m submersion for 1 hour, with I/O cable attached) IP69K (with I/O cable attached)
Shock	IEC 60068-2-27 (Amplitude: 100 g, Shape: 11 ms half-sine, 3 shocks x 6 directions)
Vibration	IEC 60068-2-64 (Amplitude: 3 G-rms, Shape: 10 - 1000 Hz, Mounting: sprung masses, 3 axes w/ 8 hr duration each)
Compliance	<p>For US</p> <p>Laser Safety:</p> <ul style="list-style-type: none"> <li>• IEC/EN 60825-1:2014 Class 1 eye safe</li> <li>• FDA US 21CFR1040 Notice 56 Class 1</li> </ul> <p>Product Safety:</p> <ul style="list-style-type: none"> <li>• UL 62368-1</li> <li>• CSA 22.2 No. 62368-1-19</li> </ul> <p>EMC: FCC 47CFR Part 15, Subpart B, Class A</p> <p>For EU</p> <p>Laser Safety: IEC/EN 60825-1:2014 Class 1 eye safe</p> <p>Product Safety: EN/IEC 62368-1</p> <p>EMC:</p> <ul style="list-style-type: none"> <li>• EN 55032:2012/AC 2013; CISPR 32:2015</li> <li>• EN 55024:2010; CISPR 24:2010</li> <li>• EN 61000-3-2:2014</li> <li>• EN 61000-3-3:2013</li> </ul> <p><b>Note:</b> Ouster UK (Ltd): 125 Princes Street, Edinburgh EH2 4AD, Scotland, United Kingdom Contact: Neil Calder, Phone Number: +44(0).131.563.9078</p> <div style="display: flex; justify-content: space-around; align-items: center;">    </div>

## ACCESSORIES

Interface Box	Polycarb/FR4, 100 g, 75 mm x 50 mm x 25 mm (LxWxH), 2 m CAT6 cable, 24 V power adapter, 5 m sensor cable
Mount	Aluminum, 530 g, 110 mm x 110 mm x 20.5 mm (LxWxH), 4 x M8 thru holes

## SOFTWARE

Sample Drivers	Ouster SDK, ROS, C++
----------------	----------------------

## EXTERIOR DIMENSIONS

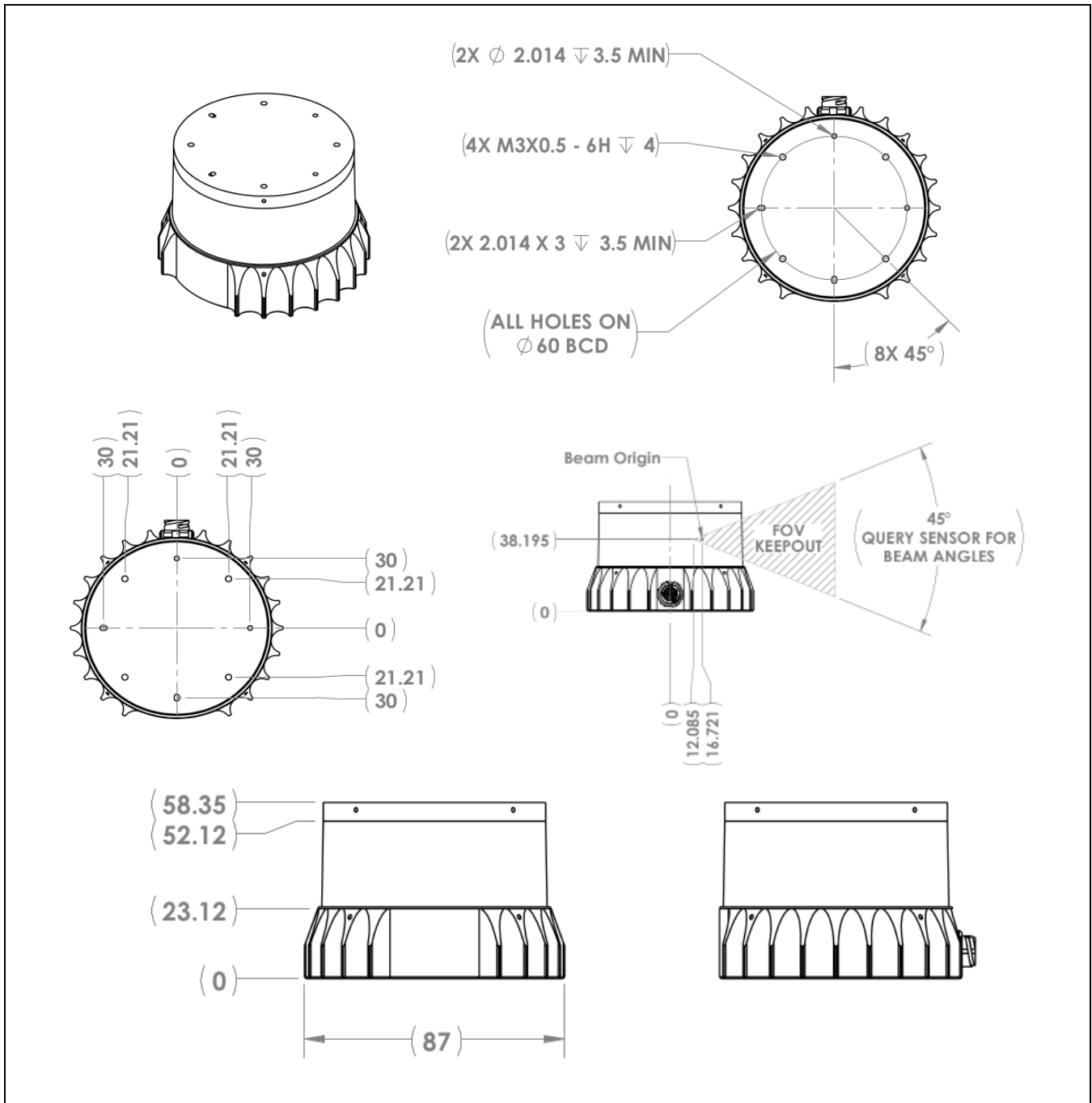

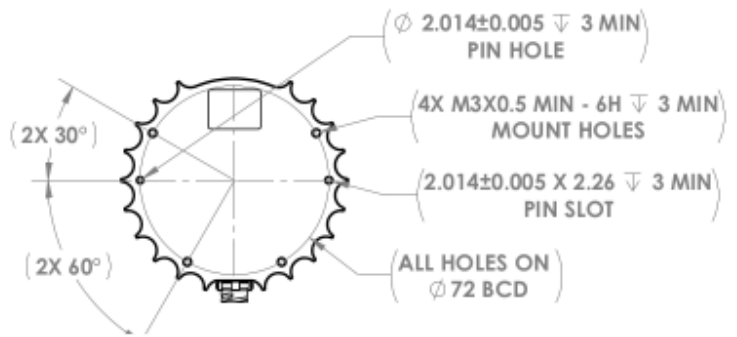
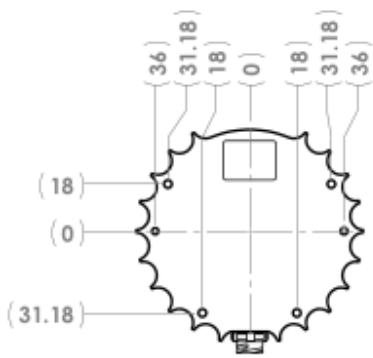

\*Specifications are subject to change without notice.

[WWW.OUSTER.COM](http://WWW.OUSTER.COM)

REV: 06/26/2023 • © 2023 Ouster, Inc. • All rights reserved

